

Linear Axis - LA20-BS Miniature Axis

Parameter	Value	Unit
Ball Screw Diameter	8	mm
Screw Lead	2.5	mm/rot
Max Vertical Load	3	kg
Max Vertical Load	2	kg
No load speed	125	mm/s
Max Dynamic Torque	90	mm/s ²
Position Accuracy	0.02	mm
Max Force	565	N
Service Life	5000	km

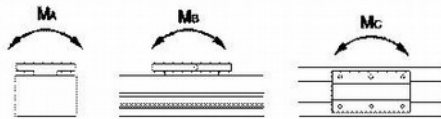

Dynamic Permissible Torque
 Ma=90Nm Mb=40Nm Mc=40Nm



Linear Axis LA20-BS-300-10-C5 - Order Code Example

LA = Linear Axis

Axis Width

20 = Miniature Axis

Effective Stroke

100-2000mm Screw linear module

100-4000mm Belt Linear Module

Screw and Belt linear module

BS=Ball Screw linear module

BL=Belt linear module

PBS=Precise screw

DBL=Double-rail belt

HND=Hand-wheel screw

Screw lead mm/rot

05 mm

10 mm

16 mm

20 mm

Screw accuracy class

C5

C7

LA20-BS Dimensions

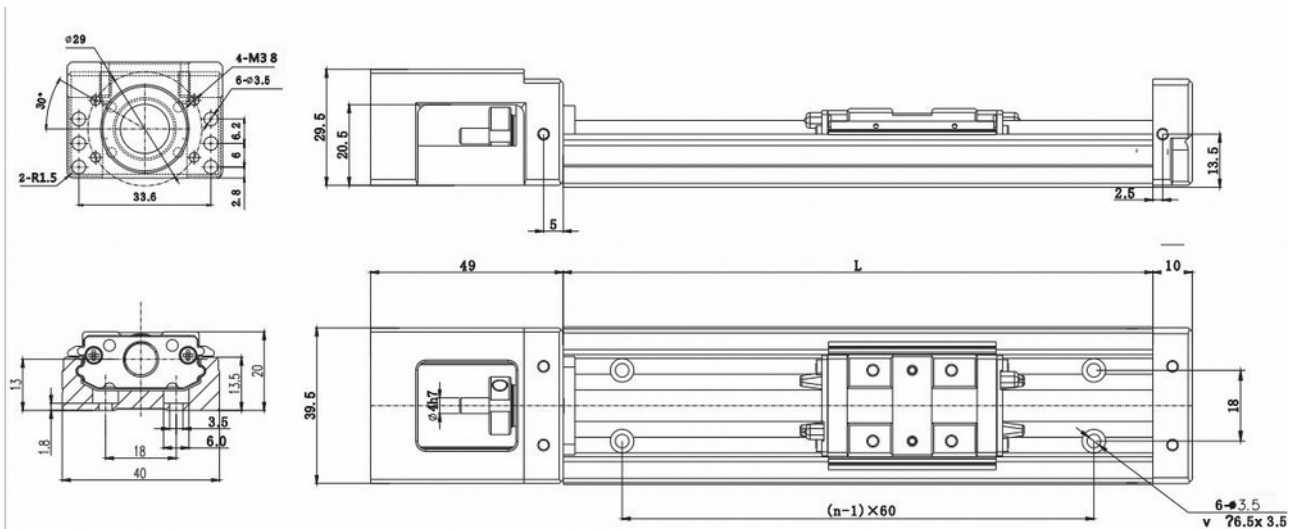

LA20-BS Ball Screw Linear Axis Configurations

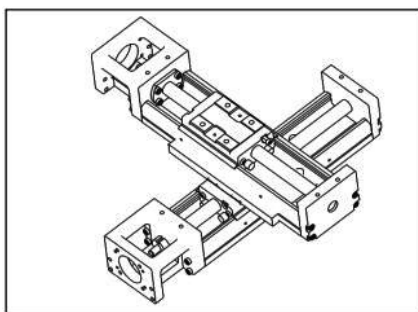

LA20-BS ... XY-S

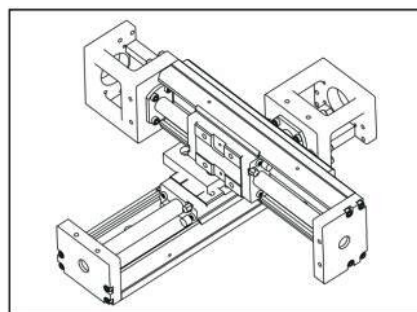

LA20-BS ... XY-X

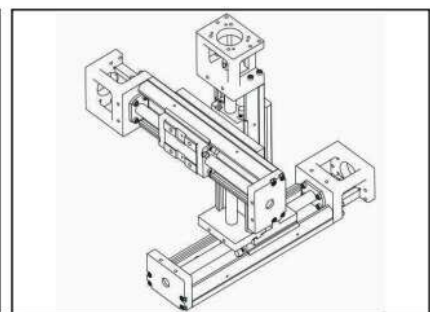

LA20-BS ... XY-T

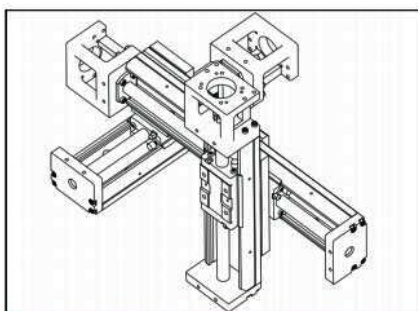

LA20-BS ... XYZ-X

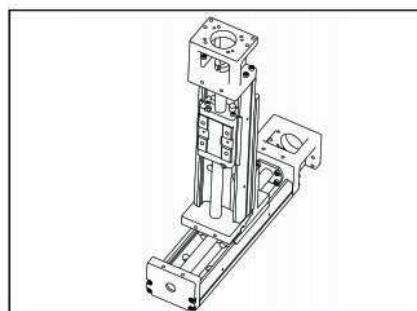

LA20-BS ... XY-T

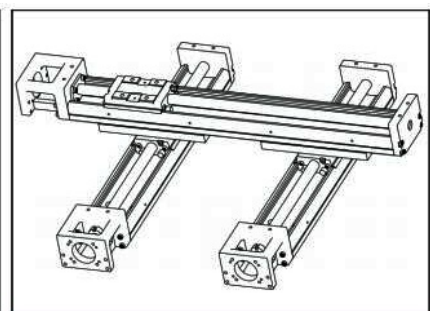

LA20-BS ... XY-H1